

Optimal solutions for your specific needs

DT Dijkstra has more than 90 years of experience in the cleaning and grading of agricultural products. We distinguish ourselves by offering total solutions.

Are you looking for knowledge and expertise to refurbish or optimize your facility? We are ready to work with you to develop the optimal equipment for your process.

Experience our personal and professional approach from the first contact until years after the installation of your project.



- Total solutions for cleaning and grading
- Thoughtful logistics
- Modular structure of processing lines
- Complete, turnkey projects
- Suitable for reliable, daily continuous use

Some examples of projects to be delivered in 2019/2020.

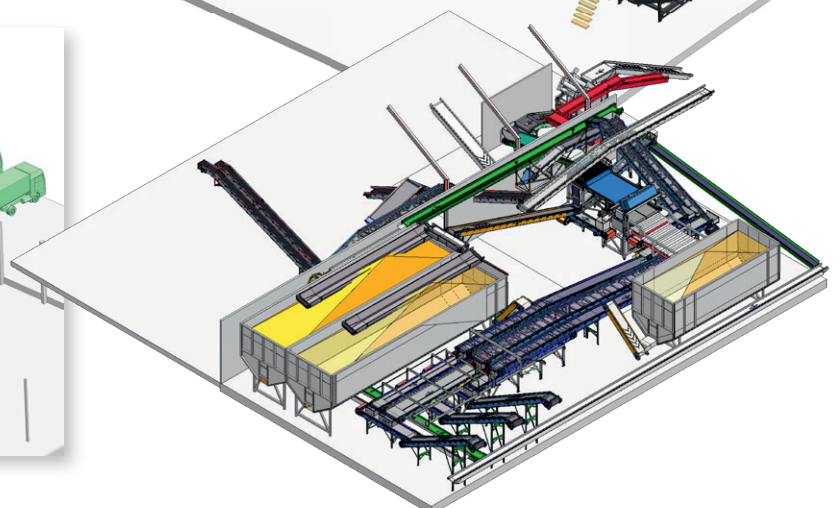
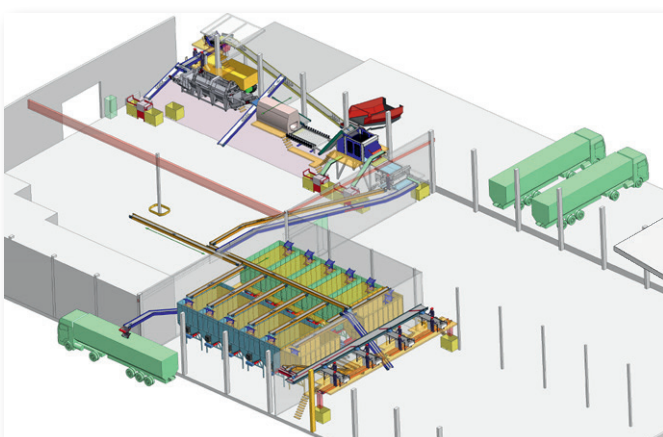
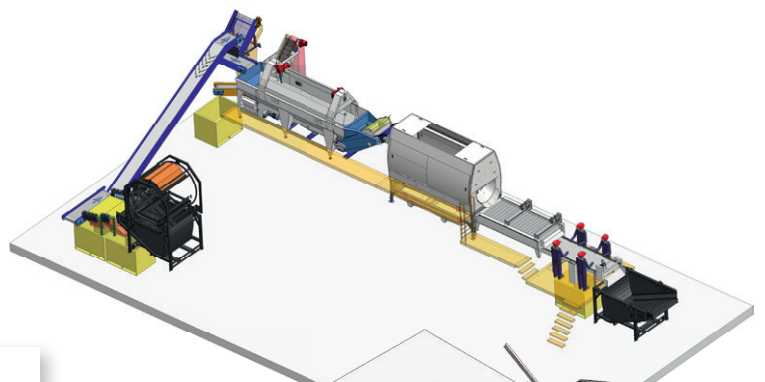

Innovation driven by experience

Enhanced affinity with customers and making more intelligent use of available resources and technologies. This is what makes DT Dijkstra stand out in the world of cleaning and grading agricultural products.

Integrated solutions

Cleaning and grading will increasingly be done by specialised grading and packaging businesses with a minimum deployment of labour. This will necessitate the availability of integrated (turnkey) systems for providing process information to the customer, enabling them to optimise their process from reception to delivery of products.

DT Dijkstra are in the business of devising innovative solutions for the cleaning and grading of potatoes, onions, bulbs, beetroot, sprouts and other bulbous and tuberous crops. Supported by the expertise and reliability for which the business has been renowned in the market for decades and based on over 90 years of experience, a young and creative team of specialists work on turnkey solutions for large and medium-sized growers, packaging businesses and producers of potato products. Standard machines are often coupled with and incorporated into client-specific installations which,

thanks to DT Dijkstra's inventiveness, frequently outperform customer expectations. The flexible efficiency of the solutions significantly reduces the cost of processing.

Innovative as well as inventive

DT Dijkstra distinguish themselves from their competitors through the innovation of products and processes, embracing original and creative ideas complemented with an integral approach to problem solving. In addition to output and flexibility, the focus will be on ergonomics, food safety, environmental burden and energy consumption.

Would you like to know more about DT Dijkstra?

Take a look at our website www.dtdijkstra.nl or call us on +31 (0)527 69 77 31.

This is DT Dijkstra:

- Distinctive in quality, personal attention and solutions
- High quality products
- Innovative
- Experienced engineers and mechanics
- Turnkey product solutions
- Thinking along with you in the buying process
- Worldwide presence
- Specialist
- Own 24/7 technical support

Wet cleaning
Optimal product-friendly cleaning of potatoes



Grading
Unrivalled in precision and quality

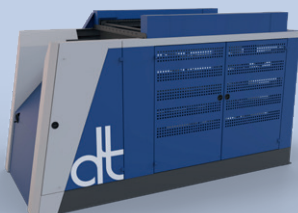

Logistics
Well thought-out solutions



Installations
Tailor-made total solutions



Grading

Unrivalled capacity and quality

The DT Dijkstra grader represents 90 years of experience, and the unique double-shaking technology with alternating stroke length remains unparalleled. A unique combination of flexibility, grading quality and capacity. Size changes can be made within just a few minutes thanks to the hydraulic fast-clamping system for the sieves.

DT Dijkstra grading machines are available in widths ranging from 1,000 to 2,400 mm (10 to 65 tons per hour).

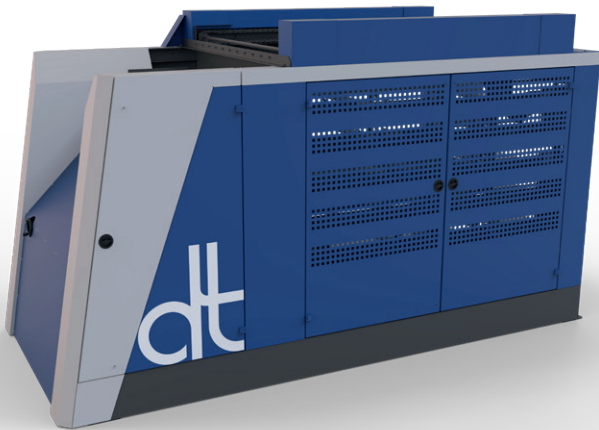

Benefits of the DT Dijkstra grading machines:

- Completely food-safe (option)
- Maximum grading capacity
- Outstanding size accuracy
- Unrivalled durability.

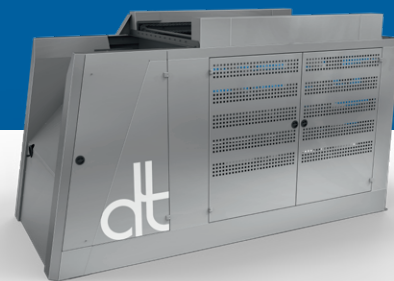

Also available in stainless steel

Wet cleaning

Reliable and highly efficient

Processing businesses prefer to have an appropriate over-capacity with a high degree of flexibility for the wet cleaning of products. DT Dijkstra offer industrial food-safe washers, with drums ranging from a diameter of 1 m and a length of 3 m. The range also includes washers with a length from 8 to 10 metres for potatoes, and a special newly-developed carrot drum can also be fitted to the washer if required. This octagonal lattice drum ensures optimum mutual rotation and rubbing of the product. An integrated auger is available to ensure an efficient and cost-positive use of washing water, whereby up to 50% can be saved on water consumption.



Benefits of the DT Dijkstra washers:

- Configured according to clients' requirements and tailor-made
- Consistent operational reliability and 'built to last'
- Completely food-safe (option)
- Water-saving integrated auger (option)
- Maximum washing flexibility
- User-friendly HMI
- Option: combination with stone, clod and haulm separator.

Visit us at Agritechnica in Hanover 10 to 16 November 2019

Experience our latest developments in grading and cleaning technology or discuss your plans for a new machine or processing line with us. We look forward to seeing you there!



Stand 24B11

Service and maintenance

Prevention is better than repair! Avoid downtime on your machine due to broken or worn parts and make your maintenance budget more transparent in advance.

Preventive maintenance

Have your installation optimally maintained and adjusted by our DT Dijkstra service specialists.

Maintenance contracts

The continuity of your installation is secured at previously agreed costs.

Components

Original quality parts according to the latest technology are quickly delivered.

To schedule maintenance or inspection:

Contact our service department via +31 (0) 527 69 77 31 or services@dttijkstra.nl.

Quick service

Our DT Dijkstra service team is ready to help you quickly and accurately in the event of an emergency.

We are available 24/7

You can rely on our service.

dt DIJKSTRA
excellent service & maintenance

Service department:
T: 0527 697 731
E: services@dttijkstra.nl
W: www.dtdijkstra.nl